

SOC3210M

Main Features

High performance RISC CPU Core

- 32bits RISC CPU Core with 266MIPS@266MHz
- MIPS32 Instruction set support
- 5 levels pipeline instruction architecture
- Integrated 16KB 4-ways I-Cache, 8KB 2-ways D-Cache
- 32-entry TLB support
- Integrated pipeline Multiply Unit

SDRAM controller

- 32bit @133MHz controller
- Maximum 256M bytes capacity
- PC100/133 compatible
- 1,2,4,8 bytes burst length support

NOR Flash controller

- 8bits or 16bits mode compliant
- Maximum 32M bytes capacity
- Byte, half word & word reading mode support
- Automatic sleep mode for power saving

NAND Flash controller

- 8bits or 16bits mode compliant
- Maximum 1Tera (1024G) bytes capacity
- Byte, half word, word & page reading mode support
- Automatic sleep mode for power saving

Host Port Interface master controller

- Infineon Vinetic series DSP chips' compatible
- Intel Demultiplexed mode & Motorola Mode

LCD controller

- 320x240, 640x480, 800x600, 1024x768, up to 1280x960 display mode support
- Configurable 16bit/8bit/4bit/2bit/1bit width colors
- 16 gray level monochromatic STN panel support
- 4096 colors STN panel support
- 65536 colors TFT panel support

Ethernet controller

- Integrated 802.3 MAC controller with 1 MII port
- 10/100Mbps compatible bit-rate

AC97 interface

- 16bit/18bit/20bit sample resolution
- Up to 48KHz high transfer bit-rate support
- 2-channels stereo output
- 1 channel microphone input

Peripheral Blocks

- 4-wires full-duplex synchronization SPI
- 1 channel UART only with TXD & RXD Pin
- Philips spec compatible I2C controller
- IEEE1149.1 compatible JTAG interface for in-circuit debug
- 10 channels GPIO interface for software control directly
- 1 channel CAN bus
- 4 external interrupt signals support

System Blocks

- Integrated two PLL to provide multiple clock frequency selection for CPU & system
- Use 5MHz external crystal
- Integrated 32 watch dog to avoid system deadlock
- Advanced interrupt controller
- Integrated DMA controller

Software

- Linux2.6 operating system
- Full tools' chains of standard SOCC design kit

Supply voltage

- Dual power system, 3.3V for I/O & 1.8V for core
- Low power consumption:
≤60mW@150MHz, ≤118mW@266MHz

Temperature range: -40°C~85°C, Industry STD.

ESD: 2KV HBM STD.

Package: QFP208 LQFP208

SOC3210M

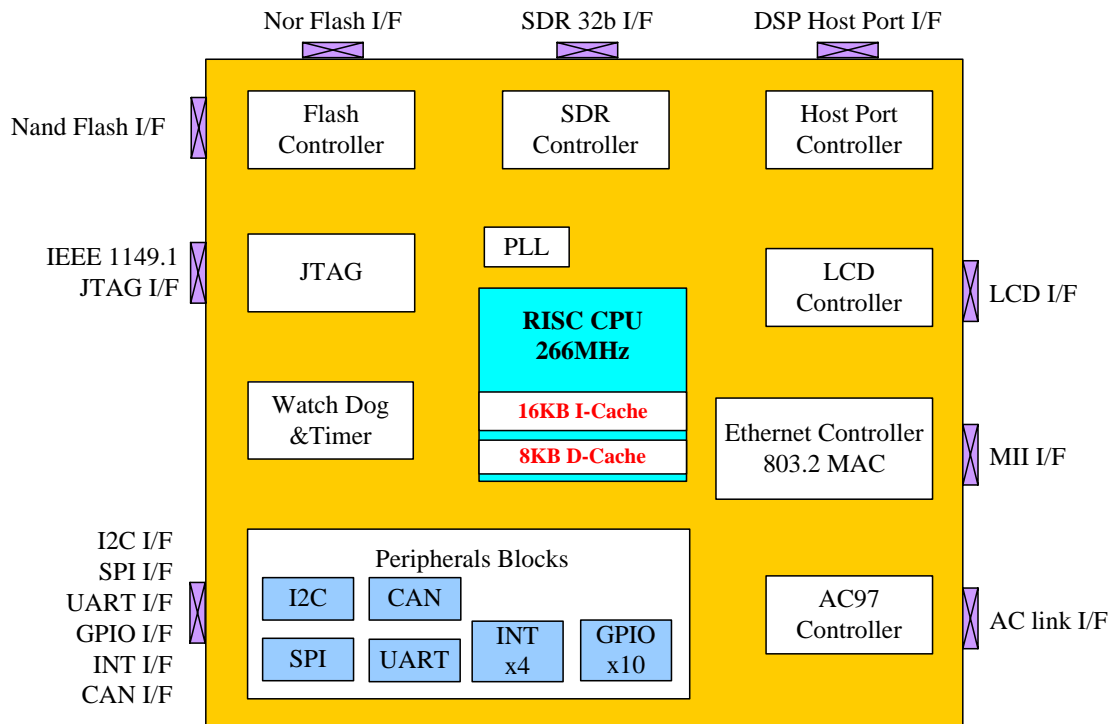

SOC3210M Function Block Diagram

Summary of Benefits

- High performance and low cost for high quality audio player & network device
- Fully integrated Ethernet Controller, LCD displayer controller, Audio Codec controller, MIPS CPU and others peripherals for low cost IP-based applications.
 - ✧ Wire or wireless audio adapter device, IP phone, WiFi phone and so on.
- Provides total solutions technical supports for customers including hardware design, software drivers & applications design.
- World-wide free standard operating systems, tools' chains & middleware support.

Electronics Specification (At 25°C)

Parameter	Symbol	Value			Unit	Memo
		Min	Typ	Max		
Core voltage	VCCINST	1.62	1.8	1.98	V	
IO voltage	VCCIO	2.97	3.3	3.63	V	
PLL voltage	AVDD18 AVDD_5AP	1.62	1.8	1.98	V	should use independent filter capacitor
Input low level logic voltage	VIL	-0.3		1.2	V	
Input high level logic voltage	VIH	1.5		5.5	V	
Input leakage current		-10			uA	
Output low logic level voltage				0.4	V	
Output high logic level voltage		2.4			V	